

Smart Highside High Current Power Switch

Reversave™

- Reverse battery protection by self turn on of power MOSFET

Features

- Overload protection
- Current limitation
- Short circuit protection
- Overtemperature protection
- Overvoltage protection (including load dump)
- Clamp of negative voltage at output
- Fast deenergizing of inductive loads ¹⁾
- Low ohmic inverse current operation
- Diagnostic feedback with load current sense
- Open load detection via current sense
- Loss of V_{bb} protection ²⁾
- **Electrostatic discharge (ESD)** protection

Application

- Power switch with current sense diagnostic feedback for 12V and 24V DC grounded loads
- Most suitable for loads with high inrush current like lamps and motors; all types of resistive and inductive loads
- Replaces electromechanical relays, fuses and discrete circuits

Product Summary

Overvoltage protection	$V_{bb(AZ)}$	62	V
Output clamp	$V_{ON(CL)}$	42	V
Operating voltage	$V_{bb(on)}$	5.0 ... 34	V
On-state resistance	R_{ON}	6.0	mΩ
Load current (ISO)	$I_{L(ISO)}$	70	A
Short circuit current limitation	$I_{L(SC)}$	130	A
Current sense ratio	$I_L : I_{IS}$	14 000	

TO 220-7

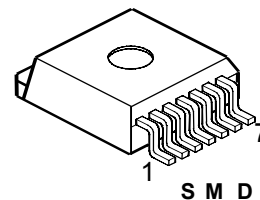

General Description

N channel vertical power FET with charge pump, current controlled input and diagnostic feedback with load current sense, integrated in Smart SIPMOS chip on chip technology. Fully protected by embedded protection functions.

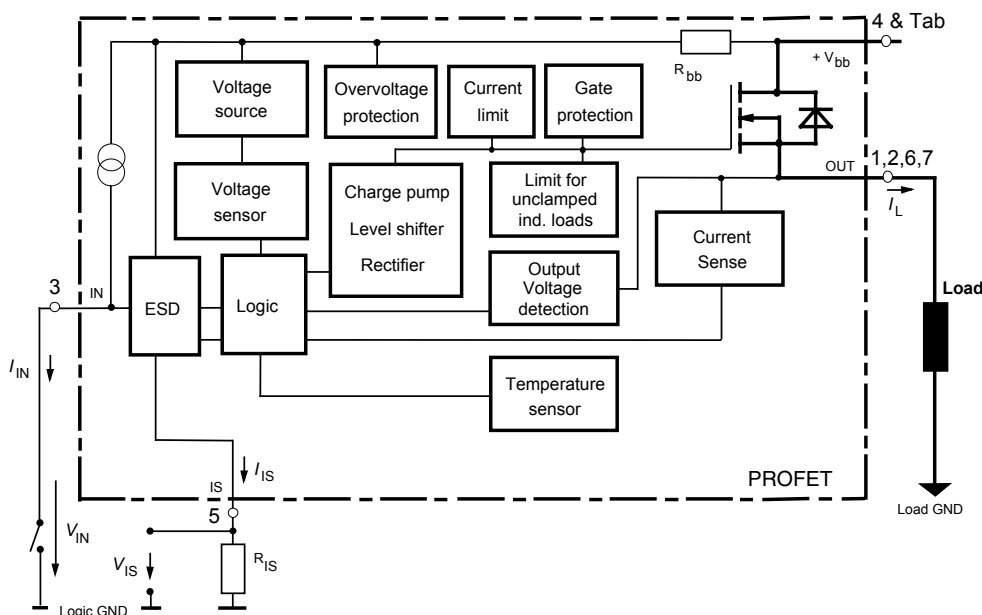

¹⁾ With additional external diode.

²⁾ Additional external diode required for energized inductive loads (see page 8).

Pin	Symbol		Function
1	OUT	O	Output to the load. The pins 1,2,6 and 7 must be shorted with each other especially in high current applications! ³⁾
2	OUT	O	Output to the load. The pins 1,2,6 and 7 must be shorted with each other especially in high current applications! ³⁾
3	IN	I	Input, activates the power switch in case of short to ground
4	V _{bb}	+	Positive power supply voltage, the tab is electrically connected to this pin. In high current applications the tab should be used for the V _{bb} connection instead of this pin ⁴⁾ .
5	IS	S	Diagnostic feedback providing a sense current proportional to the load current; zero current on failure (see Truth Table on page 6)
6	OUT	O	Output to the load. The pins 1,2,6 and 7 must be shorted with each other especially in high current applications! ³⁾
7	OUT	O	Output to the load. The pins 1,2,6 and 7 must be shorted with each other especially in high current applications! ³⁾

Maximum Ratings at T_j = 25 °C unless otherwise specified

Parameter	Symbol	Values	Unit
Supply voltage (overvoltage protection see page 4)	V _{bb}	42	V
Supply voltage for short circuit protection, T _{j,start} = -40 ... +150 °C: (E _{AS} limitation see diagram on page 9)	V _{bb}	34	V
Load current (short circuit current, see page 5)	I _L	self-limited	A
Load dump protection V _{LoadDump} = V _A + V _S , V _A = 13.5 V R _I ⁵⁾ = 2 Ω, R _L = 0.54 Ω, t _d = 200 ms, IN, IS = open or grounded	V _{Load dump} ⁶⁾	75	V
Operating temperature range	T _j	-40 ... +150	°C
Storage temperature range	T _{stg}	-55 ... +150	
Power dissipation (DC), T _C ≤ 25 °C	P _{tot}	170	W
Inductive load switch-off energy dissipation, single pulse V _{bb} = 12V, T _{j,start} = 150 °C, T _C = 150 °C const., I _L = 20 A, Z _L = 7.5 mH, 0 Ω, (see diagrams on page 9)	E _{AS}	1.5	J
Electrostatic discharge capability (ESD) Human Body Model acc. MIL-STD883D, method 3015.7 and ESD assn. std. S5.1-1993, C = 100 pF, R = 1.5 kΩ	V _{ESD}	4	kV
Current through input pin (DC)	I _{IN}	+15, -250	mA
Current through current sense status pin (DC) see internal circuit diagrams on page 7	I _{IS}	+15, -250	

³⁾ Not shorting all outputs will considerably increase the on-state resistance, reduce the peak current capability and decrease the current sense accuracy

⁴⁾ Otherwise add about 0.3 mΩ to the R_{ON} if the pin is used instead of the tab.

⁵⁾ R_I = internal resistance of the load dump test pulse generator.

⁶⁾ V_{Load dump} is setup without the DUT connected to the generator per ISO 7637-1 and DIN 40839.

Thermal Characteristics

Parameter and Conditions	Symbol	Values			Unit
		min	typ	max	
Thermal resistance chip - case: junction - ambient (free air): SMD version, device on PCB ⁸⁾ :	$R_{thJC}^{7)}$	--	--	0.75	K/W
	R_{thJA}	--	60	--	
				33	

Electrical Characteristics

Parameter and Conditions	Symbol	Values			Unit
		min	typ	max	
at $T_J = -40 \dots +150^\circ\text{C}$, $V_{bb} = 12\text{ V}$ unless otherwise specified					

Load Switching Capabilities and Characteristics

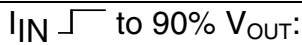
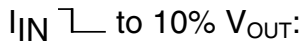
On-state resistance (Tab to pins 1,2,6,7) $I_L = 20\text{ A}$, $T_J = 25^\circ\text{C}$: $V_{IN} = 0$, $I_L = 20\text{ A}$, $T_J = 150^\circ\text{C}$: $I_L = 90\text{ A}$, $T_J = 150^\circ\text{C}$: $V_{bb} = 6\text{ V}^{9)}$, $I_L = 20\text{ A}$, $T_J = 150^\circ\text{C}$:	R_{ON} $R_{ON(Static)}$	--	4.4 7.9 -- 10	6.0 10.5 10.7 17	$\text{m}\Omega$
Nominal load current ¹⁰⁾ (Tab to pins 1,2,6,7) ISO 10483-1/6.7: $V_{ON} = 0.5\text{ V}$, $T_C = 85^\circ\text{C}$ ¹¹⁾	$I_{L(ISO)}$	55	70	--	A
Nominal load current ¹⁰⁾ , device on PCB ⁸⁾ $T_A = 85^\circ\text{C}$, $T_J \leq 150^\circ\text{C}$ $V_{ON} \leq 0.5\text{ V}$,	$I_{L(NOM)}$	13.6	17	--	A
Maximum load current in resistive range (Tab to pins 1,2,6,7) $V_{ON} = 1.8\text{ V}$, $T_C = 25^\circ\text{C}$: see diagram on page 12 $V_{ON} = 1.8\text{ V}$, $T_C = 150^\circ\text{C}$:	$I_{L(Max)}$	250 150	-- --	-- --	A
Turn-on time ¹²⁾ I_{IN}  to 90% V_{OUT} :	t_{on}	150	230	470	μs
Turn-off time I_{IN}  to 10% V_{OUT} : $R_L = 1\ \Omega$, $T_J = -40 \dots +150^\circ\text{C}$	t_{off}	80	130	200	μs
Slew rate on ¹²⁾ (10 to 30% V_{OUT}) $R_L = 1\ \Omega$, $T_J = 25^\circ\text{C}$	dV/dt_{on}	0.1	0.25	0.6	$\text{V}/\mu\text{s}$
Slew rate off ¹²⁾ (70 to 40% V_{OUT}) $R_L = 1\ \Omega$, $T_J = 25^\circ\text{C}$	$-dV/dt_{off}$	0.15	0.35	0.6	$\text{V}/\mu\text{s}$

⁷⁾ Thermal resistance R_{thCH} case to heatsink (about 0.5 ... 0.9 K/W with silicone paste) not included!

⁸⁾ Device on 50mm*50mm*1.5mm epoxy PCB FR4 with 6cm² (one layer, 70 μm thick) copper area for V_{bb} connection. PCB is vertical without blown air.

⁹⁾ Decrease of V_{bb} below 10 V causes slowly a dynamic increase of R_{ON} to a higher value of $R_{ON(Static)}$. As long as $V_{bIN} > V_{bIN(u) max}$, R_{ON} increase is less than 10 % per second for $T_J < 85^\circ\text{C}$.

¹⁰⁾ Not tested, specified by design.

¹¹⁾ T_J is about 105 $^\circ\text{C}$ under these conditions.

¹²⁾ See timing diagram on page 13.

Parameter and Conditions at $T_j = -40 \dots +150^\circ\text{C}$, $V_{bb} = 12\text{ V}$ unless otherwise specified	Symbol	Values			Unit
		min	typ	max	

Inverse Load Current Operation

On-state resistance (Pins 1,2,6,7 to pin 4) $V_{bIN} = 12\text{ V}$, $I_L = -20\text{ A}$ see page 9 $T_j = 25^\circ\text{C}$: $T_j = 150^\circ\text{C}$:	$R_{ON(inv)}$	--	4.4 7.9	6.0 10.5	$\text{m}\Omega$
Nominal inverse load current (Pins 1,2,6,7 to Tab) $V_{ON} = -0.5\text{ V}$, $T_C = 85^\circ\text{C}^{11)}$	$I_{L(inv)}$	55	70	--	A
Drain-source diode voltage ($V_{out} > V_{bb}$) $I_L = -20\text{ A}$, $I_{IN} = 0$, $T_j = +150^\circ\text{C}$	$-V_{ON}$	--	0.6	--	V

Operating Parameters

Operating voltage ($V_{IN} = 0$) ^{9, 13)}	$V_{bb(on)}$	5.0	--	34	V
Undervoltage shutdown ¹⁴⁾	$V_{bIN(u)}$	1.5	3.0	4.5	V
Undervoltage start of charge pump see diagram page 14	$V_{bIN(ucp)}$	3.0	4.5	6.0	V
Overvoltage protection ¹⁵⁾ $I_{bb} = 15\text{ mA}$	$V_{bIN(Z)}$	60 62	-- 66	-- --	V
Standby current $I_{IN} = 0$	$I_{bb(off)}$	--	15 25	25 50	μA

¹³⁾ If the device is turned on before a V_{bb} -decrease, the operating voltage range is extended down to $V_{bIN(u)}$. For all voltages 0 ... 34 V the device is fully protected against overtemperature and short circuit.

¹⁴⁾ $V_{bIN} = V_{bb} - V_{IN}$ see diagram on page 7. When V_{bIN} increases from less than $V_{bIN(u)}$ up to $V_{bIN(ucp)} = 5\text{ V}$ (typ.) the charge pump is not active and $V_{OUT} \approx V_{bb} - 3\text{ V}$.

¹⁵⁾ See also $V_{ON(CL)}$ in circuit diagram on page 8.

Parameter and Conditions at $T_j = -40 \dots +150^\circ\text{C}$, $V_{bb} = 12\text{V}$ unless otherwise specified	Symbol	Values			Unit
		min	typ	max	

Protection Functions

Short circuit current limit (Tab to pins 1,2,6,7) ¹⁶⁾ $V_{ON} = 12\text{V}$	$T_c = -40^\circ\text{C}$: $I_{L(SC)}$	--	110	--	A
	$T_c = 25^\circ\text{C}$: $I_{L(SC)}$	45	130	180	
	$T_c = +150^\circ\text{C}$: $I_{L(SC)}$	--	115	--	
Output clamp ¹⁷⁾ (inductive load switch off) see diagram Ind. and overvolt. output clamp page 7	$I_L = 40\text{mA}$: $-V_{OUT(CL)}$	14	17	20	V
Output clamp (inductive load switch off) at $V_{OUT} = V_{bb} - V_{ON(CL)}$ (e.g. overvoltage) $I_L = 40\text{mA}$	$V_{ON(CL)}$	39	42	47	V
Thermal overload trip temperature	T_{jt}	150	--	--	$^\circ\text{C}$
Thermal hysteresis	ΔT_{jt}	--	10	--	K

Reverse Battery

Reverse battery voltage ¹⁸⁾	$-V_{bb}$	--	--	32	V
On-state resistance (Pins 1,2,6,7 to pin 4) $V_{bb} = -12\text{V}$, $V_{IN} = 0$, $I_L = -20\text{A}$, $R_{IS} = 1\text{k}\Omega$	$T_j = 25^\circ\text{C}$: $R_{ON(rev)}$ $T_j = 150^\circ\text{C}$:	--	5.4 8.9	7.0 12.3	$\text{m}\Omega$
Integrated resistor in V_{bb} line	R_{bb}	--	120	--	Ω

Diagnostic Characteristics

Current sense ratio, static on-condition, $k_{ILIS} = I_L : I_{IS}$, $V_{ON} < 1.5\text{V}$ ¹⁹⁾ , $V_{IS} < V_{OUT} - 5\text{V}$, $V_{bIN} > 4.0\text{V}$ see diagram on page 11	$I_L = 90\text{A}$, $T_j = -40^\circ\text{C}$: k_{ILIS} $T_j = 25^\circ\text{C}$: $T_j = 150^\circ\text{C}$: $I_L = 20\text{A}$, $T_j = -40^\circ\text{C}$: $T_j = 25^\circ\text{C}$: $T_j = 150^\circ\text{C}$: $I_L = 10\text{A}$, $T_j = -40^\circ\text{C}$: $T_j = 25^\circ\text{C}$: $T_j = 150^\circ\text{C}$: $I_L = 4\text{A}$, $T_j = -40^\circ\text{C}$: $T_j = 25^\circ\text{C}$: $T_j = 150^\circ\text{C}$:	12 400 12 000 11 400 12 200 12 000 11 500 11 100 11 500 11 400 10 000 11 000 10 600	14 200 13 700 12 800 14 800 14 100 13 200 15 300 14 500 13 300 17 600 15 600 13 800	16 000 15 400 14 200 17 400 16 200 15 000 19 500 17 500 15 200 28 500 22 000 18 000	
$I_{IS} = 0$ by $I_{IN} = 0$ (e.g. during deenergizing of inductive loads):					
Sense current saturation	$I_{IS,lim}$	6.5	--	--	mA

¹⁶⁾ Short circuit is a failure mode. The device is not designed to operate continuously into a short circuit. The lifetime will be reduced under such conditions.

¹⁷⁾ This output clamp can be "switched off" by using an additional diode at the IS-Pin (see page 7). If the diode is used, V_{OUT} is clamped to $V_{bb} - V_{ON(CL)}$ at inductive load switch off.

¹⁸⁾ The reverse load current through the intrinsic drain-source diode has to be limited by the connected load (as it is done with all polarity symmetric loads). Note that under off-conditions ($I_{IN} = I_{IS} = 0$) the power transistor is not activated. This results in raised power dissipation due to the higher voltage drop across the intrinsic drain-source diode. The temperature protection is not active during reverse current operation! Increasing reverse battery voltage capability is simply possible as described on page 8.

¹⁹⁾ If V_{ON} is higher, the sense current is no longer proportional to the load current due to sense current saturation, see $I_{IS,lim}$.

Parameter and Conditions at $T_j = -40 \dots +150^\circ\text{C}$, $V_{bb} = 12\text{V}$ unless otherwise specified	Symbol	Values			Unit
		min	typ	max	
Current sense leakage current $I_{IN} = 0$: $V_{IN} = 0$, $I_L \leq 0$:	$I_{IS(LL)}$	--	--	0.5	μA
	$I_{IS(LH)}$	--	2	--	
Current sense overvoltage protection $I_{bb} = 15\text{mA}$ $T_j = -40^\circ\text{C}$: $T_j = 25\dots+150^\circ\text{C}$:	$V_{bIS(Z)}$	60	--	--	V
		62	66	--	
Current sense settling time ²⁰⁾	$t_{s(IS)}$	--	--	500	μs
Input					
Input and operating current (see diagram page 12) IN grounded ($V_{IN} = 0$)	$I_{IN(on)}$	--	0.8	1.5	mA
Input current for turn-off ²¹⁾	$I_{IN(off)}$	--	--	80	μA

Truth Table

	Input current level	Output level	Current Sense I_{IS}	Remark
Normal operation	L H	L H	0 nominal	$= I_L / k_{IIS}$, up to $I_{IS} = I_{IS,lim}$
Very high load current	H	H	$I_{IS,lim}$	up to $V_{ON} = V_{ON(Fold\ back)}$ I_{IS} no longer proportional to I_L
Current-limitation	H	H	0	$V_{ON} > V_{ON(Fold\ back)}$
Short circuit to GND	L H	L L	0 0	
Over-temperature	L H	L L	0 0	
Short circuit to V_{bb}	L H	H H	0 <nominal ²²⁾	
Open load	L H	Z ²³⁾ H	0 0	
Negative output voltage clamp	L	L	0	
Inverse load current	L H	H H	0 0	

L = "Low" Level

H = "High" Level

Overtemperature reset by cooling: $T_j < T_{jt}$ (see diagram on page 14)

²⁰⁾ Not tested, specified by design.

²¹⁾ We recommend the resistance between IN and GND to be less than 0.5 k Ω for turn-on and more than 500k Ω for turn-off. Consider that when the device is switched off ($I_{IN} = 0$) the voltage between IN and GND reaches almost V_{bb} .

²²⁾ Low ohmic short to V_{bb} may reduce the output current I_L and can thus be detected via the sense current I_{IS} .

²³⁾ Power Transistor "OFF", potential defined by external impedance.

Terms

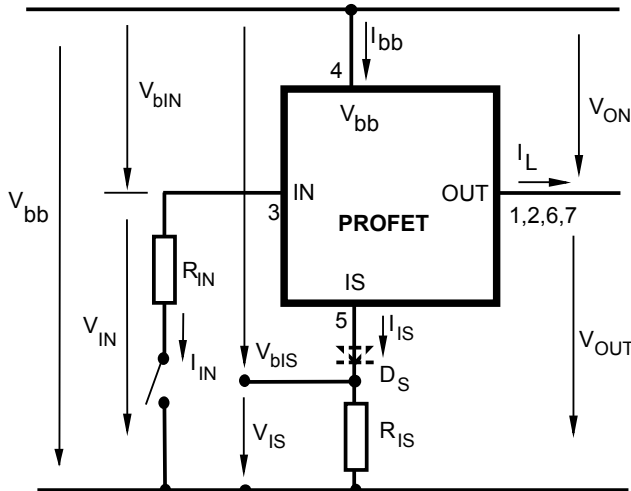

Two or more devices can easily be connected in parallel to increase load current capability.

Input circuit (ESD protection)

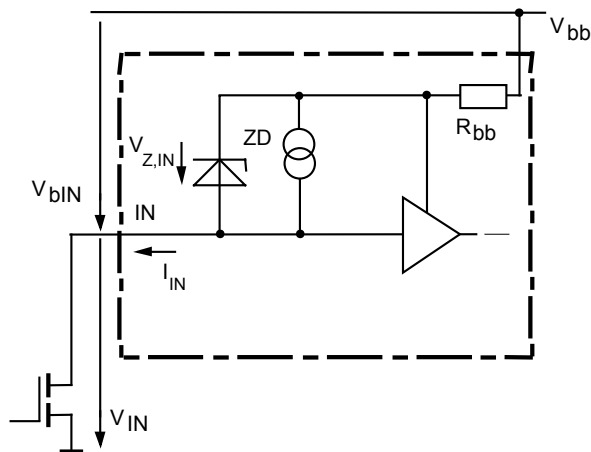

When the device is switched off ($I_{IN} = 0$) the voltage between IN and GND reaches almost V_{bb} . Use a mechanical switch, a bipolar or MOS transistor with appropriate breakdown voltage as driver. $V_{Z,IN} = 66\text{ V (typ.)}$.

Current sense status output

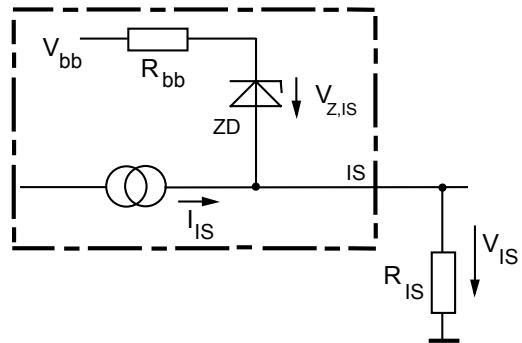

$V_{Z,IS} = 66\text{ V (typ.)}$, $R_{IS} = 1\text{ k}\Omega$ nominal (or $1\text{ k}\Omega / n$, if n devices are connected in parallel). $I_S = I_L / k_{iis}$ can be driven only by the internal circuit as long as $V_{OUT} - V_{IS} > 5\text{ V}$. If you want measure load currents up to $I_{L(M)}$, R_{IS} should be less than $\frac{V_{bb} - 5\text{ V}}{I_{L(M)} / K_{iis}}$.

Note: For large values of R_{IS} the voltage V_{IS} can reach almost V_{bb} . See also overvoltage protection. If you don't use the current sense output in your application, you can leave it open.

Inductive and overvoltage output clamp

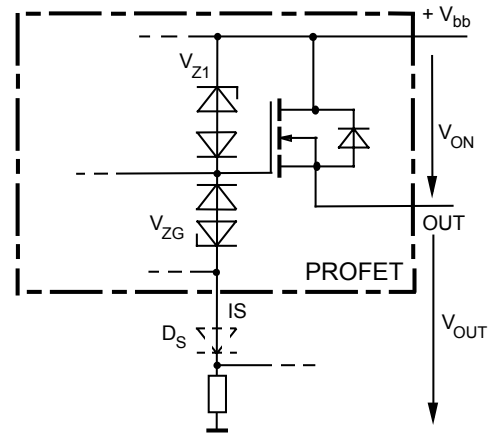

V_{ON} is clamped to $V_{ON(CL)} = 42\text{ V typ.}$ At inductive load switch-off without D_S , V_{OUT} is clamped to $V_{OUT(CL)} = -19\text{ V typ.}$ via V_{ZG} . With D_S , V_{OUT} is clamped to $V_{bb} - V_{ON(CL)}$ via V_{Z1} . Using D_S gives faster deenergizing of the inductive load, but higher peak power dissipation in the PROFET. In case of a floating ground with a potential higher than 19V referring to the OUT – potential the device will switch on, if diode D_S is not used.

Overvoltage protection of logic part

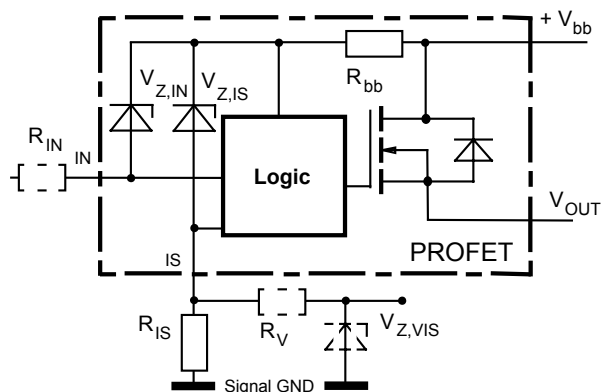

$R_{bb} = 120\Omega$ typ., $V_{Z,IN} = V_{Z,IS} = 66V$ typ., $R_{IS} = 1k\Omega$ nominal. Note that when overvoltage exceeds 71 V typ. a voltage above 5V can occur between IS and GND, if $R_V, V_{Z,VIS}$ are not used.

Reverse battery protection

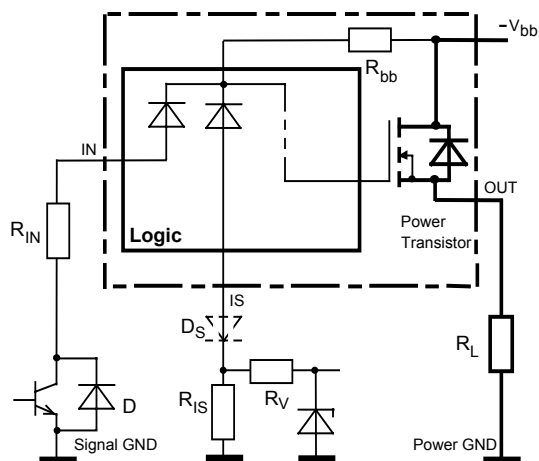

$R_V \geq 1k\Omega$, $R_{IS} = 1k\Omega$ nominal. Add R_{IN} for reverse battery protection in applications with V_{bb} above 16 V¹⁸⁾; recommended value: $\frac{1}{R_{IN}} + \frac{1}{R_{IS}} + \frac{1}{R_V} = \frac{0.1A}{|V_{bb}| - 12V}$ if D_S is not used (or $\frac{1}{R_{IN}} = \frac{0.1A}{|V_{bb}| - 12V}$ if D_S is used).

To minimize power dissipation at reverse battery operation, the summarized current into the IN and IS pin should be about 120mA. The current can be provided by using a small signal diode D in parallel to the input switch, by using a MOSFET input switch or by proper adjusting the current through R_{IS} and R_V .

V_{bb} disconnect with energized inductive load

Provide a current path with load current capability by using a diode, a Z-diode, or a varistor. ($V_{ZL} < 72V$ or $V_{Zb} < 30V$ if $R_{IN}=0$). For higher clamp voltages currents at IN and IS have to be limited to 250 mA.

Version a:

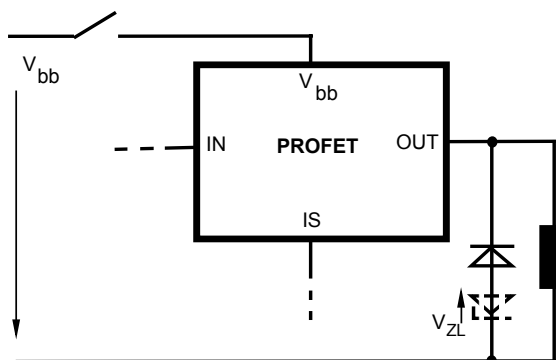

Version b:

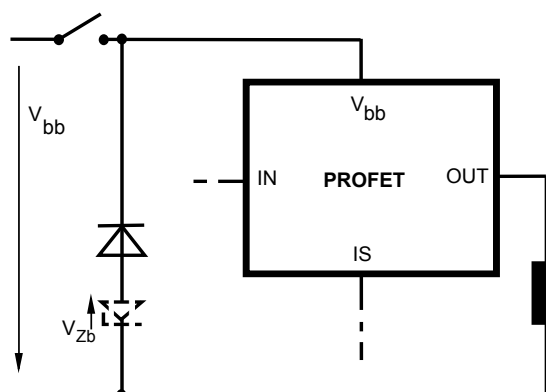

Note that there is no reverse battery protection when using a diode without additional Z-diode V_{ZL}, V_{Zb} .

Version c: Sometimes a necessary voltage clamp is given by non inductive loads R_L connected to the same switch and eliminates the need of clamping circuit:

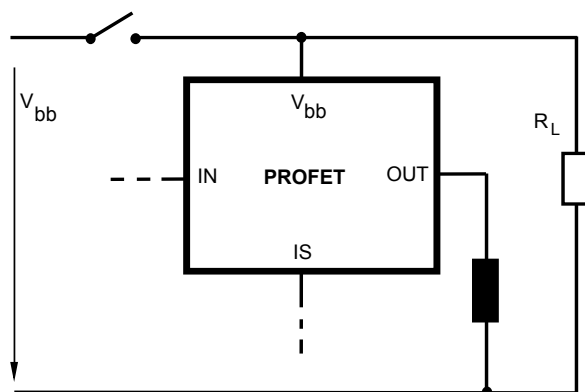

Inverse load current operation

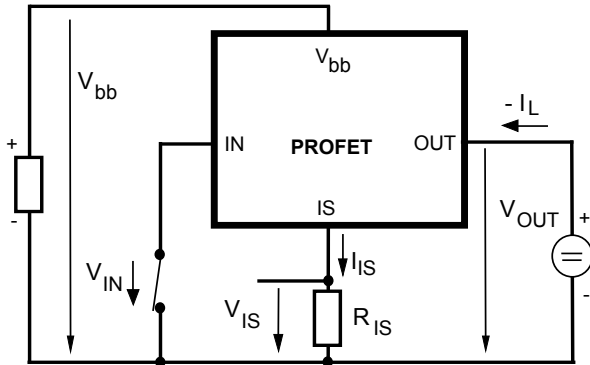

The device is specified for inverse load current operation ($V_{OUT} > V_{bb} > 0V$). The current sense feature is not available during this kind of operation ($I_{IS} = 0$). With $I_{IN} = 0$ (e.g. input open) only the intrinsic drain source diode is conducting resulting in considerably increased power dissipation. If the device is switched on ($V_{IN} = 0$), this power dissipation is decreased to the much lower value $R_{ON(INV)} \cdot I^2$ (specifications see page 4).

Note: Temperature protection during inverse load current operation is not possible!

Inductive load switch-off energy dissipation

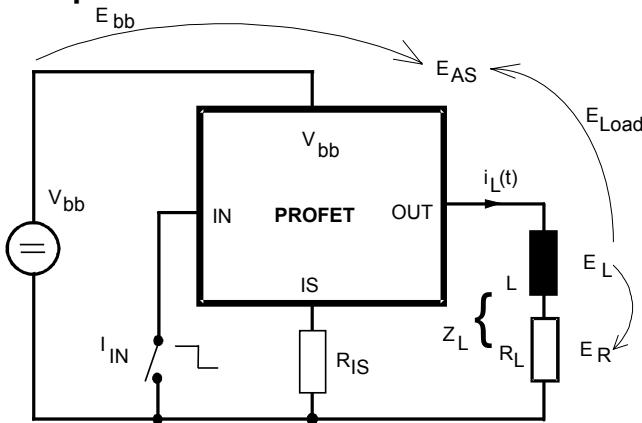

Energy stored in load inductance:

$$E_L = \frac{1}{2} \cdot L \cdot I_L^2$$

While demagnetizing load inductance, the energy dissipated in PROFET is

$$E_{AS} = E_{bb} + E_L - E_R = V_{ON(CL)} \cdot i_L(t) dt,$$

with an approximate solution for $R_L > 0\Omega$:

$$E_{AS} = \frac{I_L \cdot L}{2 \cdot R_L} (V_{bb} + |V_{OUT(CL)}|) \ln \left(1 + \frac{I_L \cdot R_L}{|V_{OUT(CL)}|} \right)$$

Maximum allowable load inductance for a single switch off

$$L = f(I_L); T_{j,start} = 150^\circ C, V_{bb} = 12V, R_L = 0\Omega$$

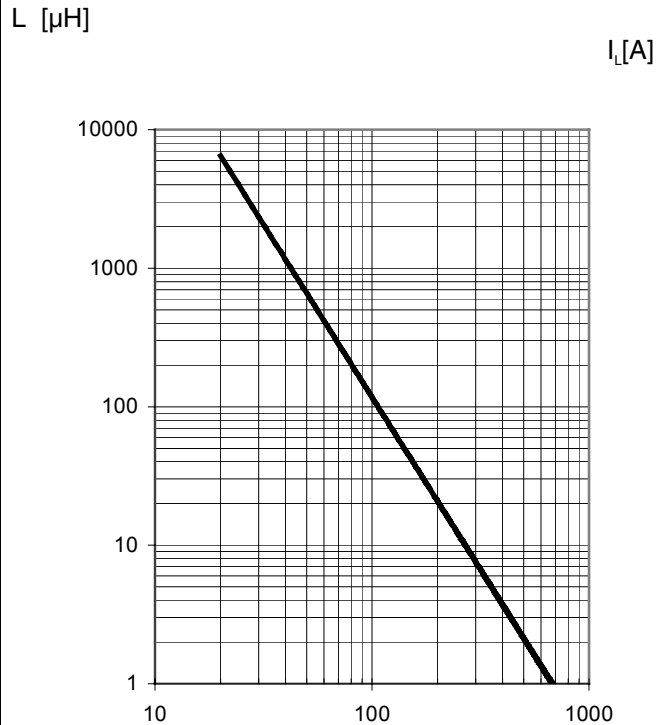

Externally adjustable current limit

If the device is conducting, the sense current can be used to reduce the short circuit current and allow higher lead inductance (see diagram above). The device will be turned off, if the threshold voltage of T2 is reached by $I_s \cdot R_{IS}$. After a delay time defined by $R_V \cdot C_V$ T1 will be reset. The device is turned on again, the short circuit current is defined by $I_{L(SC)}$.

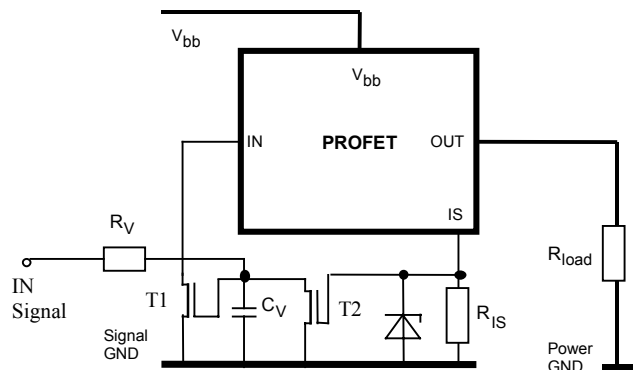

Options Overview

Type	BTS	6510P	550P 650P	555
Overtemperature protection with hysteresis $T_j > 150\text{ }^\circ\text{C}$, latch function ²⁴⁾		X	X	X
$T_j > 150\text{ }^\circ\text{C}$, with auto-restart on cooling		X	X	X
Short circuit to GND protection with overtemperature shutdown switches off when $V_{ON} > 6\text{ V}$ typ. (when first turned on after approx. 180 μs)		X	X	X
Overtemperature shutdown		-	-	-
Output negative voltage transient limit to $V_{bb} - V_{ON(CL)}$ to $V_{OUT} = -19\text{ V}$ typ		X X ²⁵⁾	X X ²⁵⁾	X X ²⁵⁾

²⁴⁾ Latch except when $V_{bb} - V_{OUT} < V_{ON(SC)}$ after shutdown. In most cases $V_{OUT} = 0\text{ V}$ after shutdown ($V_{OUT} \neq 0\text{ V}$ only if forced externally). So the device remains latched unless $V_{bb} < V_{ON(SC)}$ (see page 5). No latch between turn on and $t_{d(SC)}$.

²⁵⁾ Can be "switched off" by using a diode D_S (see page 8) or leaving open the current sense output.

Characteristics

Current sense versus load current:

$I_{IS} = f(I_L), T_J = -40 \dots +150 \text{ }^\circ\text{C}$

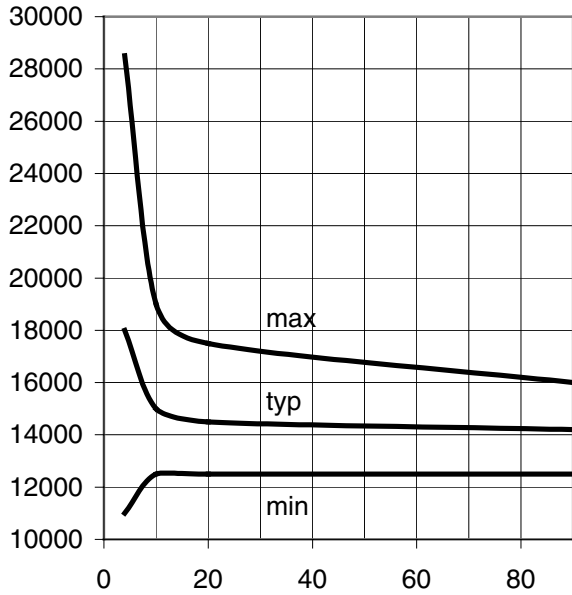

I_{IS} [mA]

I_L [A]

Current sense ratio:

$K_{ILIS} = f(I_L), T_J = -40^\circ\text{C}$

k_{ILIS}

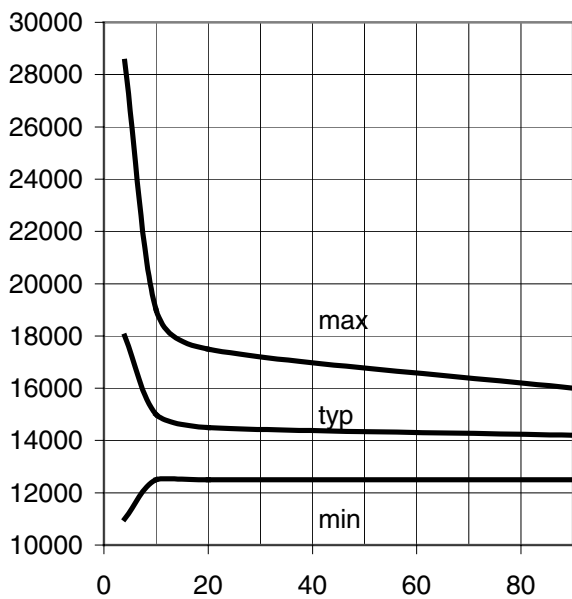

I_L [A]

Current sense ratio:

$I_{IS} = f(I_L), T_J = 25 \text{ }^\circ\text{C}$

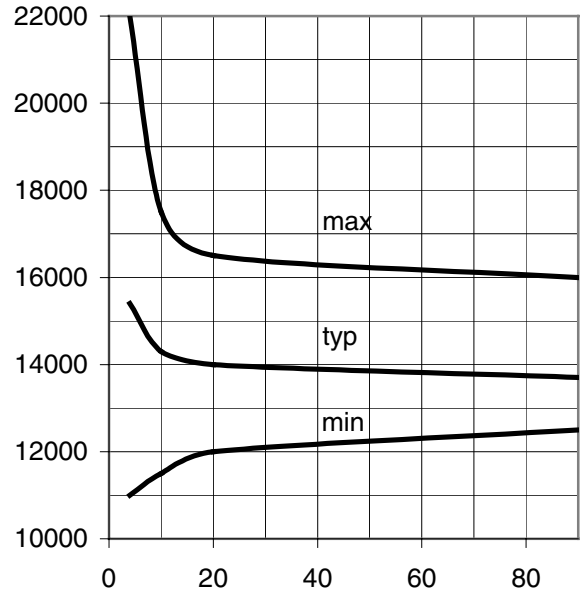

k_{ILIS}

I_L [A]

Current sense ratio:

$K_{ILIS} = f(I_L), T_J = 150^\circ\text{C}$

k_{ILIS}

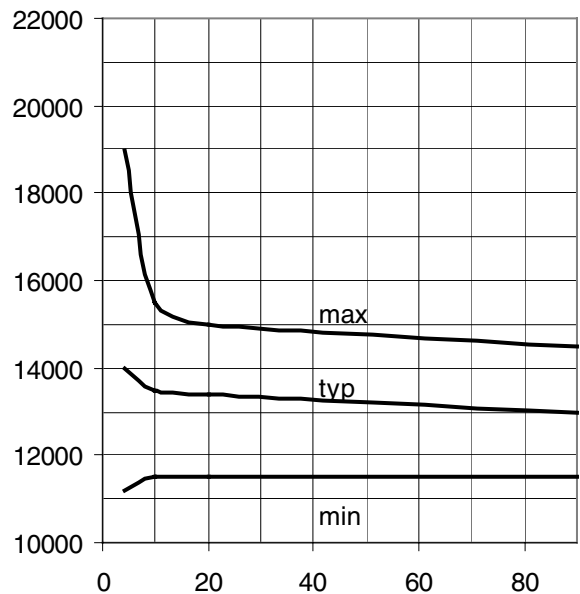

I_L [A]

Typ. current limitation characteristic
 $I_L = f(V_{ON}, T_j)$

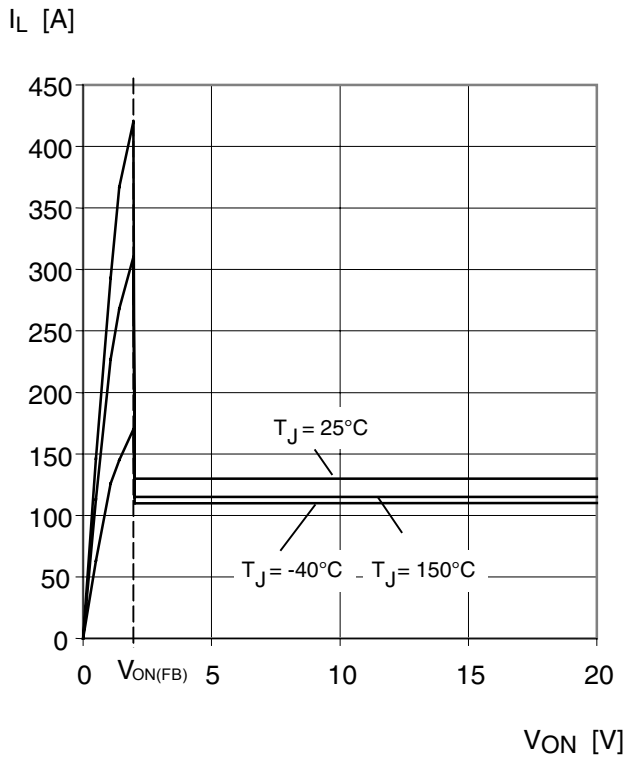

Typ. input current
 $I_{IN} = f(V_{bIN}), V_{bIN} = V_{bb} - V_{IN}$
 I_{IN} [mA]

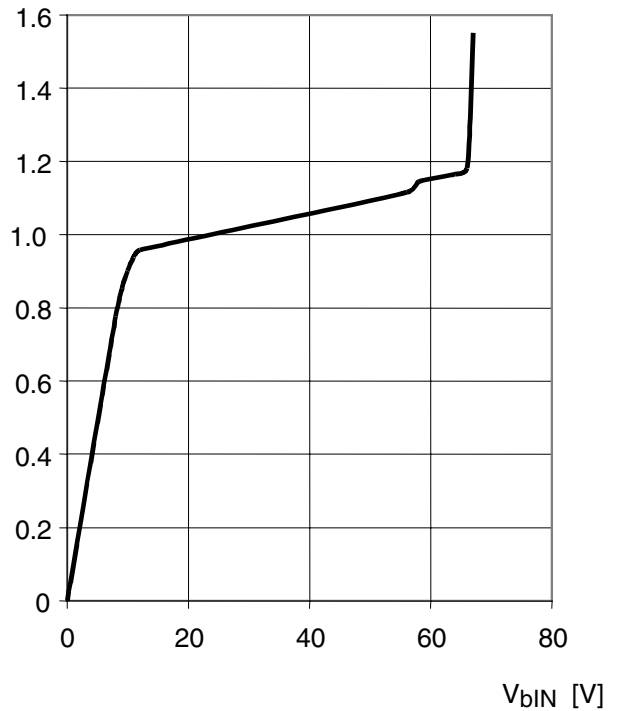

Typ. on-state resistance
 $R_{ON} = f(V_{bb}, T_j); I_L = 20\text{ A}; V_{IN} = 0$

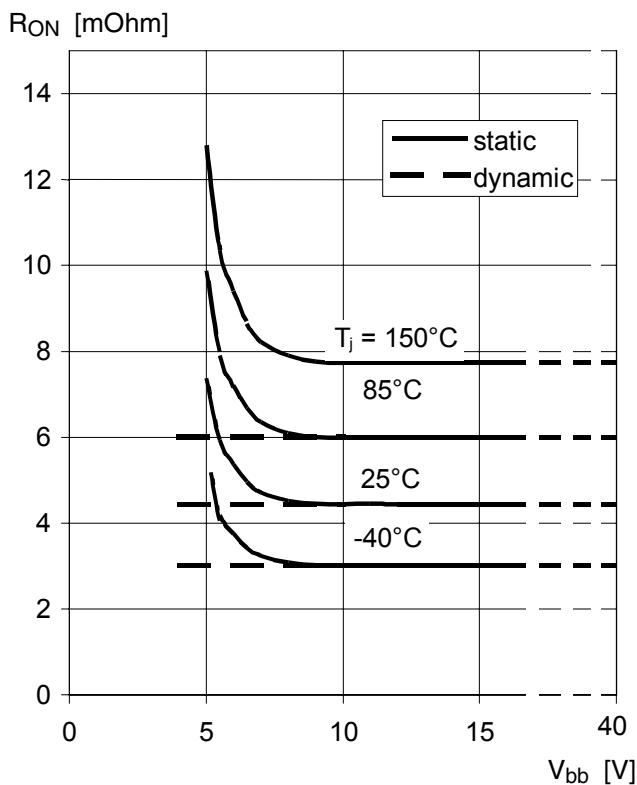

Timing diagrams

Figure 1a: Switching a resistive load, change of load current in on-condition:

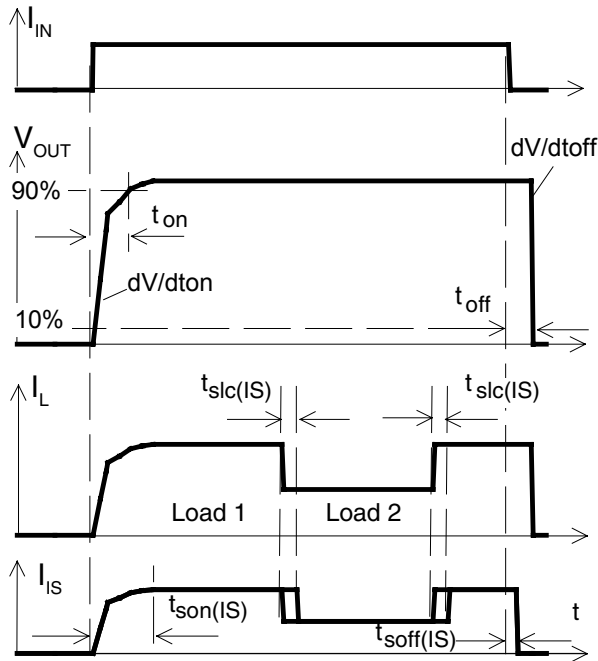

The sense signal is not valid during a settling time after turn-on/off and after change of load current.

Figure 2a: Switching motors and lamps:

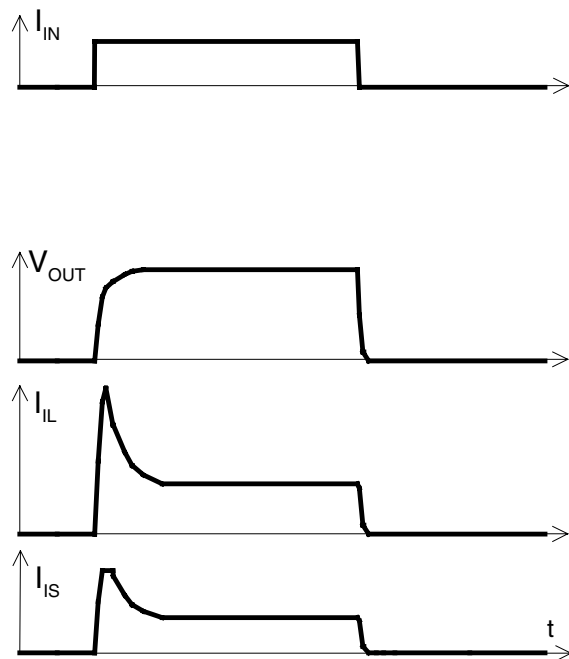

Sense current saturation can occur at very high inrush currents (see $I_{IS,lim}$ on page 5).

Figure 2b: Switching an inductive load:

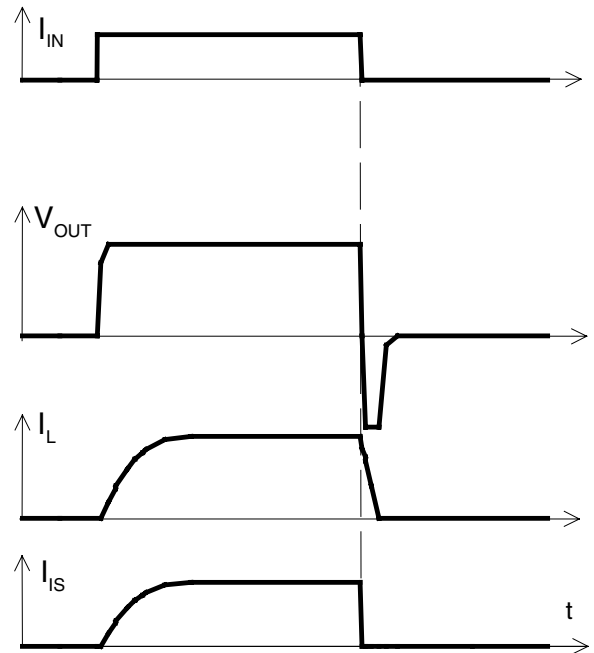

Figure 3a: Short circuit:

shut down by overtemperature detection with auto restart on cooling

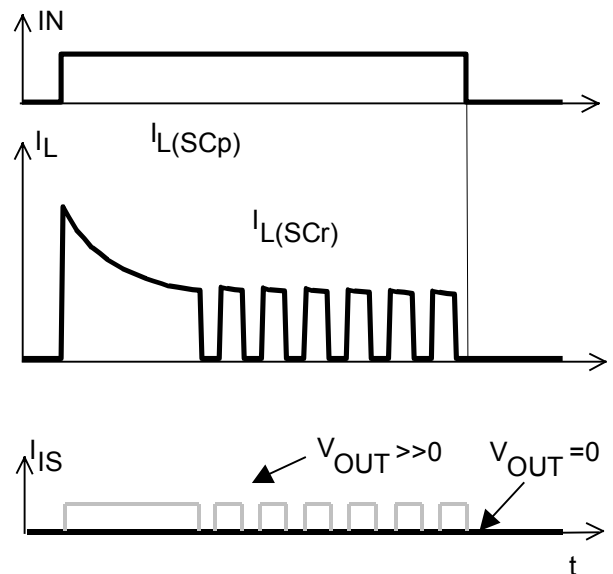

Figure 4a: Overtemperature Reset if $T_j < T_{jt}$

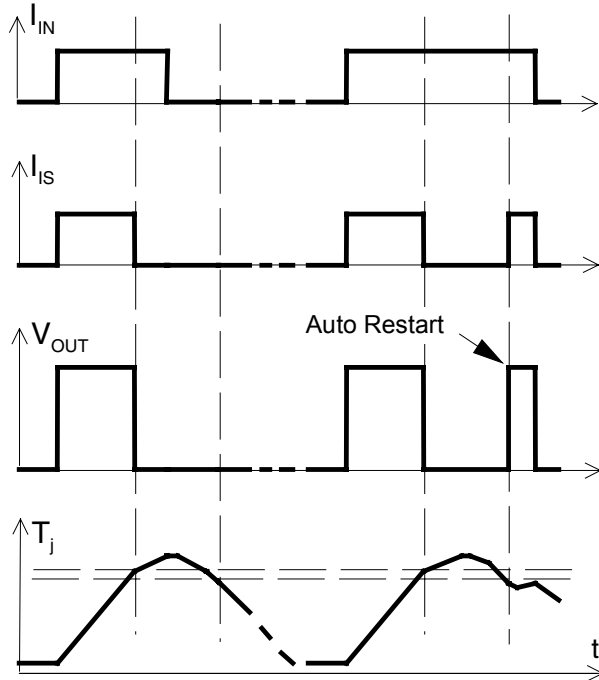
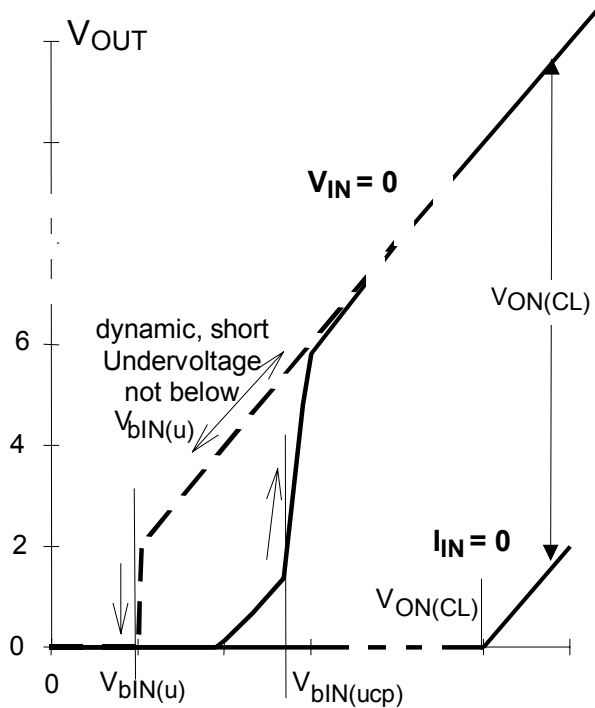

Figure 6a: Undervoltage restart of charge pump, overvoltage clamp



Package and Ordering Code

All dimensions in mm

SMD TO 220-7,

Ordering code

BTS 6510 B	T&R:	Q67060-S6311
------------	------	--------------

Published by
Infineon Technologies AG i Gr.,
Bereichs Kommunikation
St.-Martin-Strasse 76,
D-81541 München
© Infineon Technologies AG 1999
All Rights Reserved.

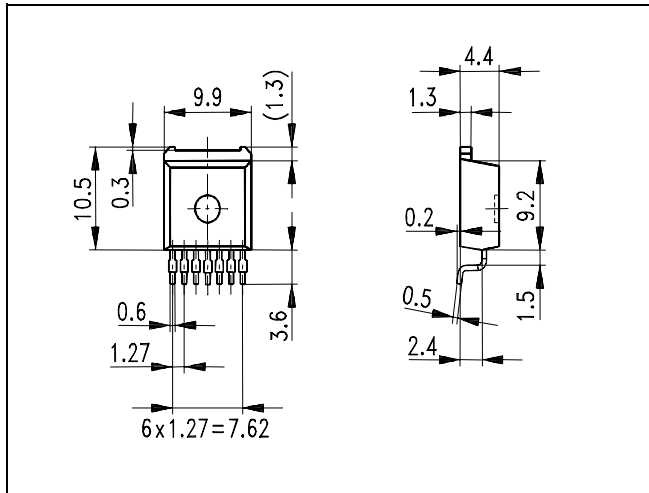

Footprint:

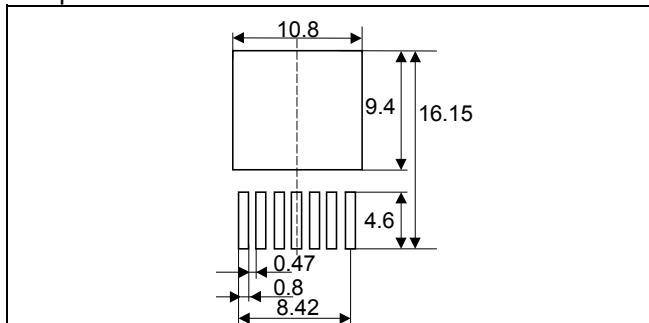

Attention please!

The information herein is given to describe certain components and shall not be considered as warranted characteristics.

Terms of delivery and rights to technical change reserved.

We hereby disclaim any and all warranties, including but not limited to warranties of non-infringement, regarding circuits, descriptions and charts stated herein.

Infineon Technologies is an approved CECC manufacturer.

Information

For further information on technology, delivery terms and conditions and prices please contact your nearest Infineon Technologies Office in Germany or our Infineon Technologies Representatives worldwide (see address list).

Warnings

Due to technical requirements components may contain dangerous substances. For information on the types in question please contact your nearest Infineon Technologies Office.

Infineon Technologies Components may only be used in life-support devices or systems with the express written approval of Infineon Technologies, if a failure of such components can reasonably be expected to cause the failure of that life-support device or system, or to affect the safety or effectiveness of that device or system. Life support devices or systems are intended to be implanted in the human body, or to support and/or maintain and sustain and/or protect human life. If they fail, it is reasonable to assume that the health of the user or other persons may be endangered.